

FULLY AUTOMATED MEASUREMENT DEVICE

UWUK[®]



FULLY AUTOMATED SYSTEM FOR BALE ISOLATION, WEIGHING AND LABELLING.

ADVANTAGES

- Live data on all warehouse stock for transparent and efficient inventory management
- Reduced deployment of staff for general materials and warehouse logistics
- Traceability and accounting for processed material streams
- Productivity increases in the upstream channel baling press through recipe optimisation thanks to feedback from the data recorded
- Visualisation of all process data and evaluation options via dashboard
- Operation of the channel baling press in the optimal energy/performance ratio, avoiding operating errors in inputting and adjusting discrete processing recipes
- Full integration of UPAMAT with UWUK in the bunker management system of a sorting plant. This is where, in conjunction, the automatic recording of fill levels and values for individual collecting bunkers takes place for the continuous and volume-appropriate feeding of the press

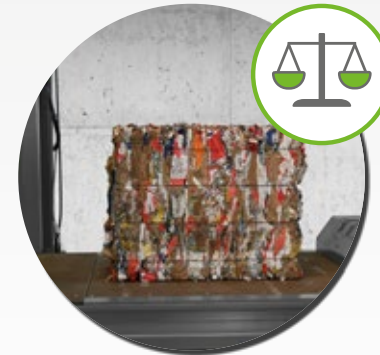
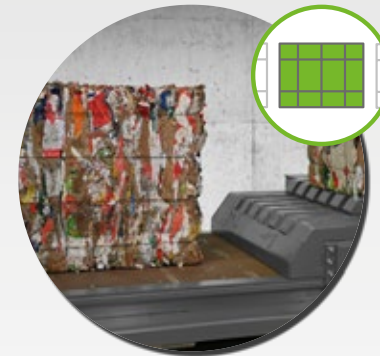

BALE ISOLATION

- The “bale isolation” process always takes place in connection with fully automated channel baling presses of the UPAMAT range
- Frequency-regulated main drive for continuous synchronisation of the processing speeds between bale isolation and the upstream channel baling press

BALE WEIGHING

- Provision of individual pressed bales to the platform scales
- Precise recording of the bale weight
- Dynamic recording of further physical parameters such as bale length, volume and density
- Transfer of all recorded measurement data to a higher-level database system

BALE LABELLING

- Onward transport of the bale to the labelling station
- In the labelling station, bales belted with one or more plastic tapes on which the data recorded previously are printed and fully visible
- Return of isolated and labelled bales to form a bale line



UPAMAT
CHANNEL BALING PRESS

UWUK
UNOTECH WEIGHING AND LABELLING

MADE IN GERMANY



FULLY AUTOMATED MEASUREMENT DEVICE

UWUK[®]

UPAMAT CHANNEL BALING PRESS

UWUK UNOTECH WEIGHING AND LABELLING

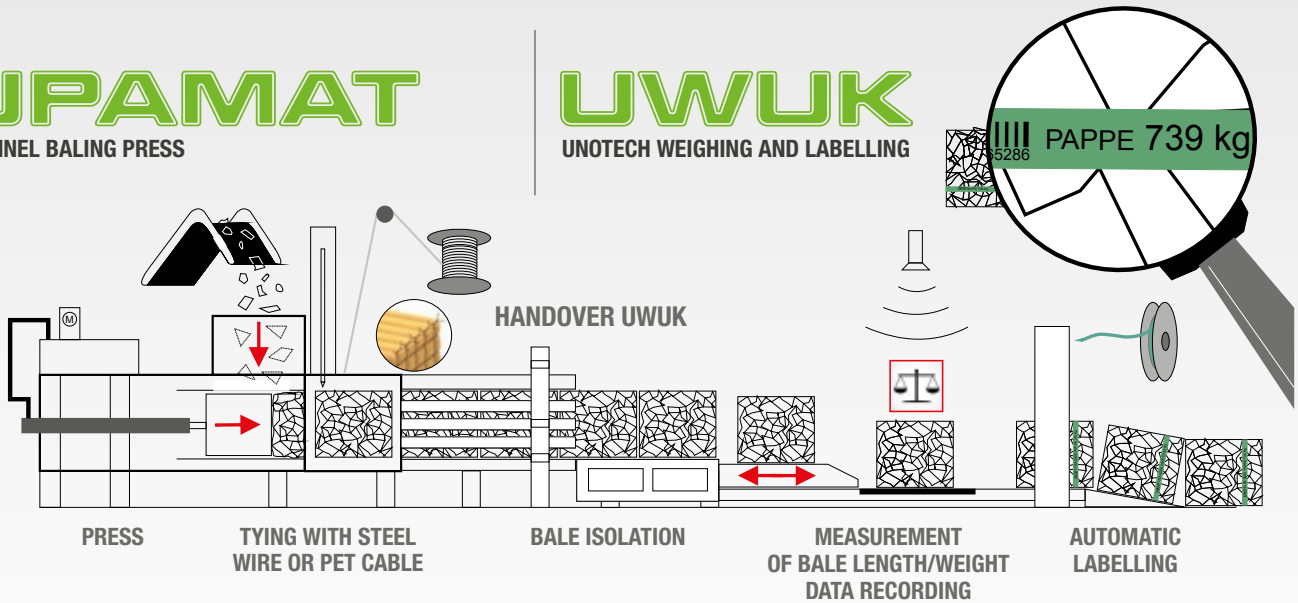

DIMENSIONS	A	B	C	D	E	F	G
UWUK	10.590	4.410	3.610	945	508	3.162	3.894

Subject to changes in design and dimensions!

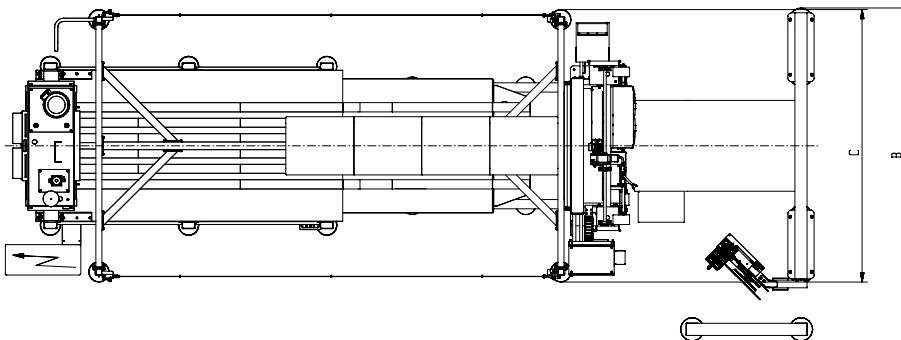
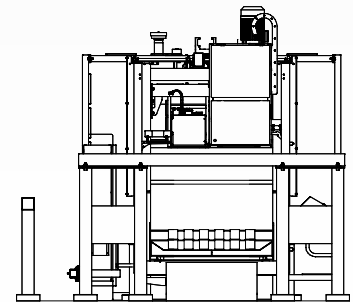
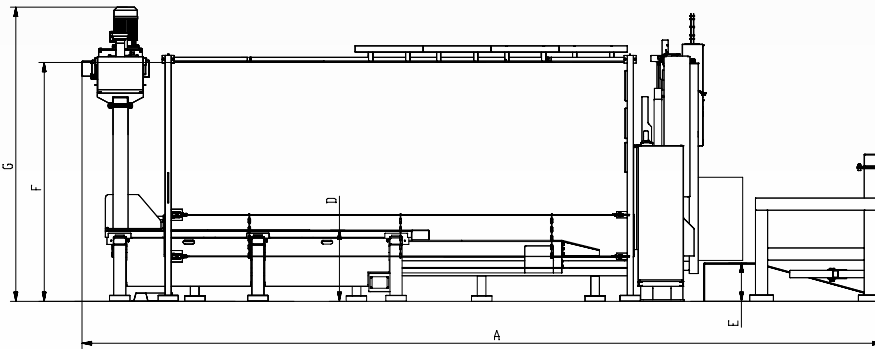

unoTech GmbH • Feldkoppel 17 • 49779 Niederlangen • Germany
Phone +49 5939 / 94 144 - 11 • Fax: +49 5939 / 94 144 - 30
info@unotech.de • www.unotech.de

